

Replacing a Leyland FWD clutch

Expert

21

On most front-wheel-drive cars the clutch cannot be removed without first removing the gearbox and drive shafts, and in some cases also the engine. But on some FWD BL cars the procedure is much simpler, the clutch being renewable with the engine and gearbox left in place.

Wiring connections

The first task is to gain access to the clutch cover. In most cases it is necessary to remove the battery and its tray for this. But on the Mini, all that is necessary is to disconnect the battery to prevent accidental short circuits. However, the bonnet will need removing from this car.

Other items to be stripped from a Mini are the ignition shield (if fitted), the coil and its bracket (though if it is attached to the cylinder head there is no need to disconnect the wiring), the plastic air intake attached to the

inner wing panel of later models and the horn if it is mounted on the bonnet lock platform.

Some 1100/1300s and Minis have the starter solenoid attached to the clutch housing, in which case the wiring should be disconnected and the solenoid removed. Alternatively, you may find the coil in the same position; this should also be removed. If the Mini's starter solenoid is attached to the inner wing panel, remove it too.

On all models, disconnect the wiring to the starter motor (making a note of the connections if it is a pre-engaged unit) and remove the starter motor itself.

Mechanical work

If a return spring is fitted between the clutch slave cylinder and release lever, unhook it at both ends. Then unbolt the slave cylinder from the

Tools and materials

- Spanners, sockets and screwdrivers
- Axle stands, jack and wood block
- Pliers
- Flywheel puller
- Feeler gauges
- Torque wrench
- Thin drift and hammer
- Soft-faced hammer
- New lockwashers
- New clutch parts as needed
- Molybdenum disulphide grease

Which model?

These sheets cover removing the clutch from the following BL cars. Some aspects of the job differ depending on whether the car has an A-series or an E-series engine.

A-series Mini, Riley Elf, Wolseley Hornet, Metro, 1100/1300, Allegro 1000/1100/1300

E-series Allegro 1500/1750, Maxi, 2200, Princess/Ambassador 2200

Inside a Leyland clutch

The majority of BL front-wheel-drive cars, from the Mini to some versions of the Princess and Ambassador, have the gearbox in the engine sump, and the clutch mounted in a separate cover on the left-hand side of the engine (looking from the front).

The clutch can be removed without disturbing any other components, though on some models you may need a special puller to remove the flywheel.

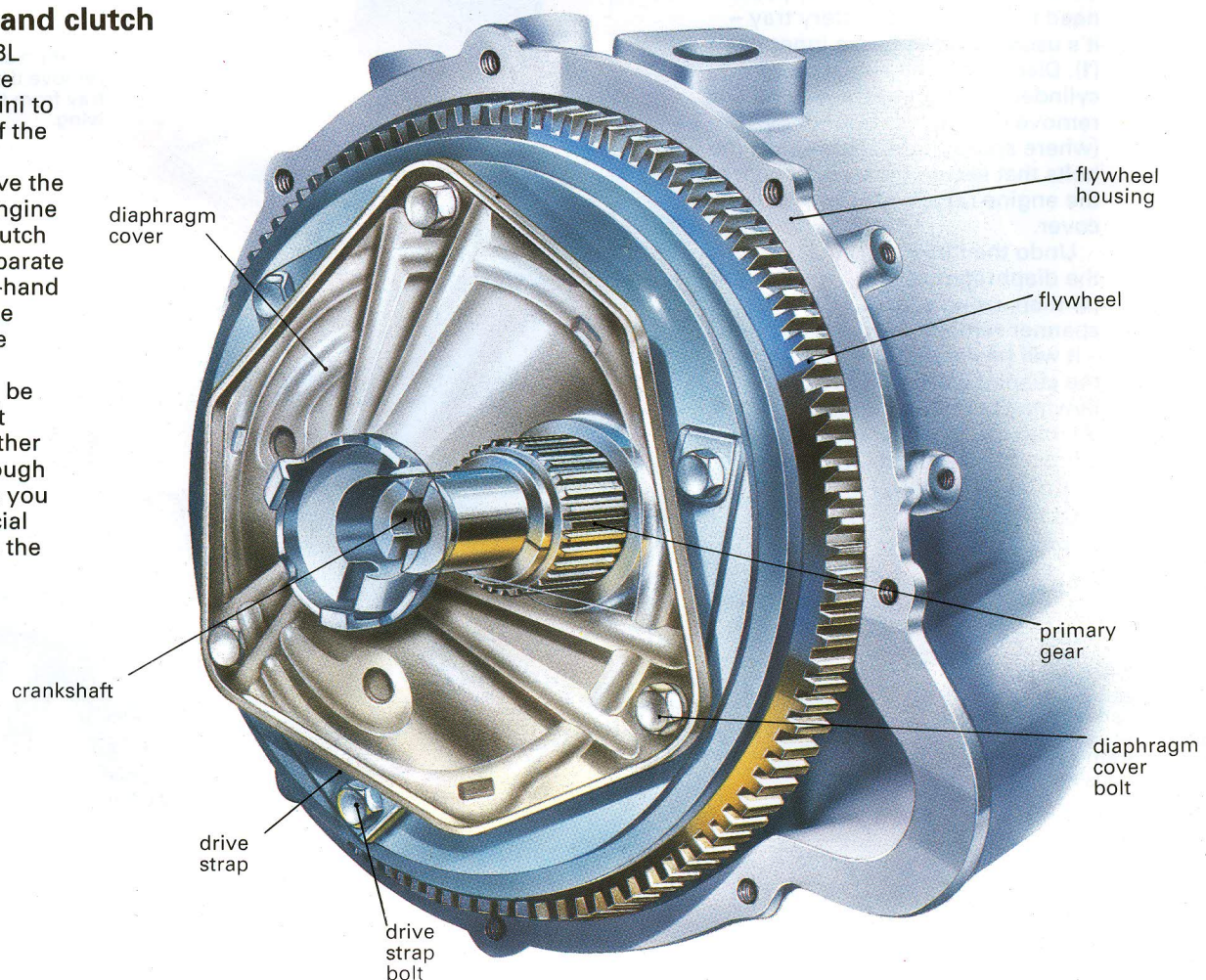

Release bearing

To remove the release bearing, take out the release lever fulcrum pin and disconnect the lever from the release bearing plunger, having first noted the way in which the fulcrum pin and lever are fitted. If there is a throw-out stop on the end of the plunger, unscrew its locking nut and remove the stop. Then withdraw the plunger and bearing from the clutch cover.

Check that the bearing runs smoothly. A bluish colour indicates overheating, while if it feels rough dirt may have got in.

Some bearings are a press fit on the plunger and can be removed and replaced with a vice and suitable tubular packing; others are held by a locking ring which can be prised free.

To replace the bearing, simply wedge the release lever with a block of wood so that the plunger's shoulder protrudes from its bore, fit the bearing and push on a new clip using hand pressure only on a suitable tubular drift.

flywheel housing and pull it carefully back from the release lever's push-rod.

On both the Mini and the 1100/1300 you will also need to take off the upper radiator support bracket, and the air filter on the Mini and the engine steady rod on the 1100/1300 (if fitted). On both of these cars, disconnect the exhaust downpipe from the manifold and free the pipe from its clip on the gearbox casing (for the Mini) and the gear lever extension housing (for the 1100/1300). In the case of the Mini you will have to jack up the car and support it on axle stands beneath the sub-frame side members.

On all models, position a jack beneath the gearbox casing, with a block of wood on the cradle to spread the load. Raise the jack until it just takes the weight from the engine mountings, then remove the appropriate mounting.

On the Mini and 1100/1300, raise the engine/gearbox assembly on the

jack to gain enough room to allow the clutch cover to be removed. Be careful when doing this because as the engine tilts, the cooling fan will come close to the radiator and may damage the core if you lift the engine too far.

Finally, on all cars with A-series engines, turn the engine over so that it is set at top dead centre. This positions a C-washer on the crankshaft correctly. If you don't do this, the washer can fall down as you remove the clutch and jam the whole assembly!

Clutch cover

Release the bolts holding the clutch housing in place and lift it away to reveal the clutch and flywheel assembly. Although the assembly is essentially the same throughout the range of models, there are detail differences which affect the way in which it is removed and dismantled.

In some cases, alignment marks in

Step-by-step clutch removal

On all cars except the Mini, you'll need to remove the battery tray – it's usually bolted to the inner wing (1). Disconnect the clutch slave cylinder (2), support the engine and remove the engine mountings (where appropriate). Next undo the bolts that secure the clutch cover to the engine (3) and lift away the cover.

Undo the three bolts that secure the diaphragm cover to the flywheel (4) then, using a large socket, or spanner remove the flywheel nut (5) – it will be very tight – followed by the shaped washer. Attach the flywheel puller and tighten it down (6) until the flywheel comes loose. Lift out the flywheel (7) – take care, as it will be heavy.

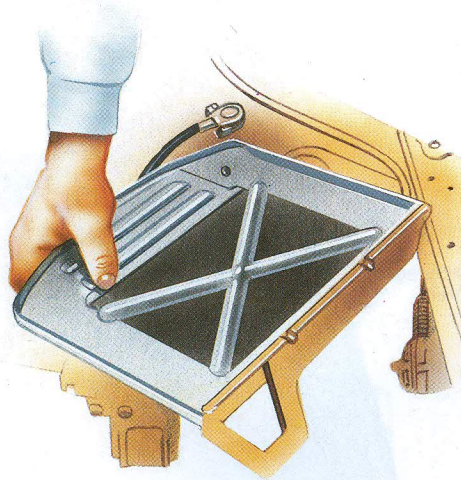

1 Unbolt and remove the battery tray from the inner wing.

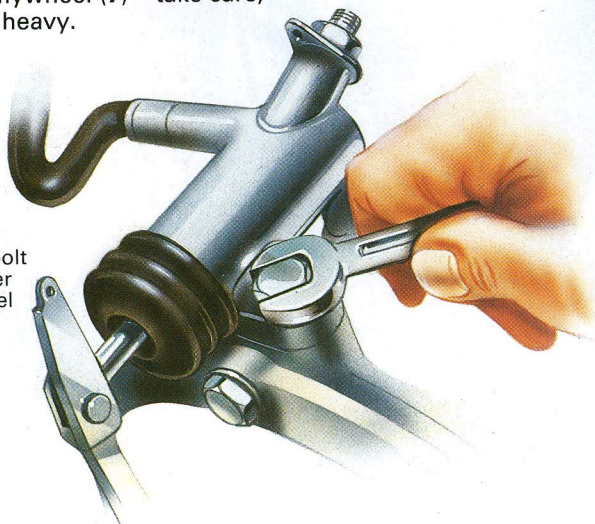

2 Release the clutch return spring, then unbolt the slave cylinder from the flywheel housing.

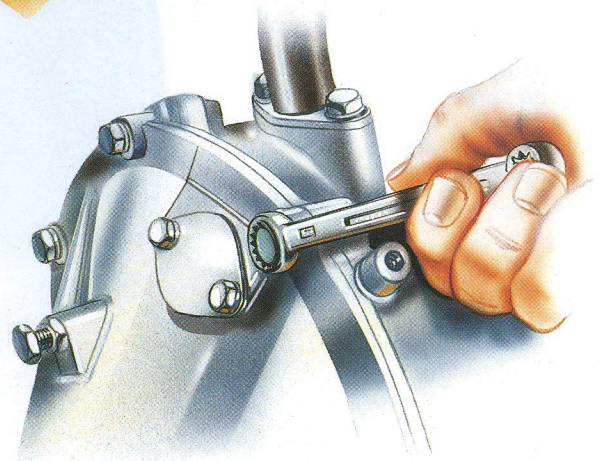

3 Unbolt the clutch cover from the flywheel housing.

the form of a letter 'A' are stamped on the diaphragm cover, flywheel and pressure plate. If you cannot find any, make your own alignment marks for reassembly.

Flywheel

On all cars with A-series engines, the flywheel is held to the crankshaft by a large central nut. To get at this nut release the three bolts securing the diaphragm cover to the flywheel pressure plate. Knock back the lock-washer tabs and unscrew the retaining bolt. Then take off the lockwasher followed by the keyed washer.

The flywheel and clutch assembly are a tight fit on the end of the crankshaft and you need a special puller to remove it. Screw the puller into the threaded holes that are already

machined in the flywheel. Turn the central bolt to draw the flywheel off the crank – lift off the flywheel (it's heavy!). Be careful how you do this, as the pressure plate and friction plate will be loose behind it. Pull the friction plate from the splined primary gear and lift out the pressure plate.

For details of how to remove the flywheel on an E-series engine, see sideline right.

Components check

Check the friction plate, pressure plate and diaphragm or coil spring assembly for signs of wear, damage, overheating or oil contamination.

Also check the driving straps for signs of distortion, overheating or elongation of the fixing holes, and examine the splines on the primary

E-series flywheel

On cars with E-series engines the flywheel is held to the end of the crankshaft by bolts.

Undo the three small bolts holding the thrust plate to the clutch diaphragm. Using a long T-bar and a socket on an extension, undo the six bolts (they will be very tight) and remove them.

Ask a friend to support the flywheel while you knock it free using a soft-faced hammer through the starter motor aperture. The clutch comes off complete with the flywheel.

4 Slacken, then remove the bolts holding the diaphragm cover in place and lift off the cover.

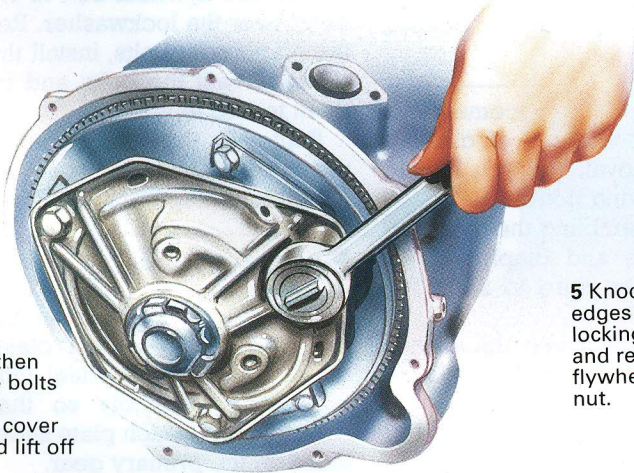

5 Knock back the edges of the locking tab washer and remove the flywheel securing nut.

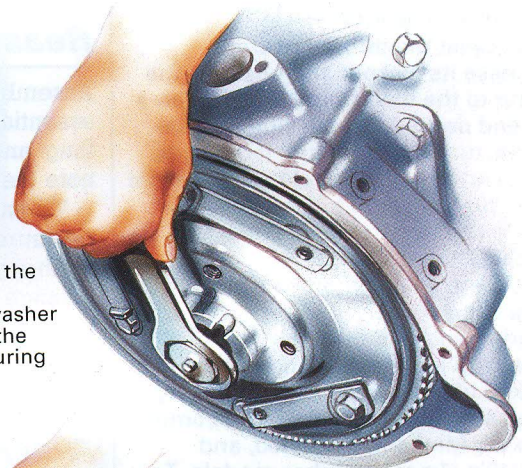

6 Use a special flywheel puller to ease the flywheel from the end of the crankshaft.

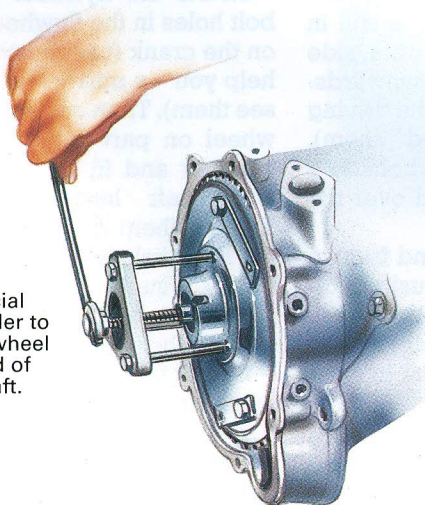

7 Lift off the flywheel – the pressure plate and friction plate are now exposed ready for removal.

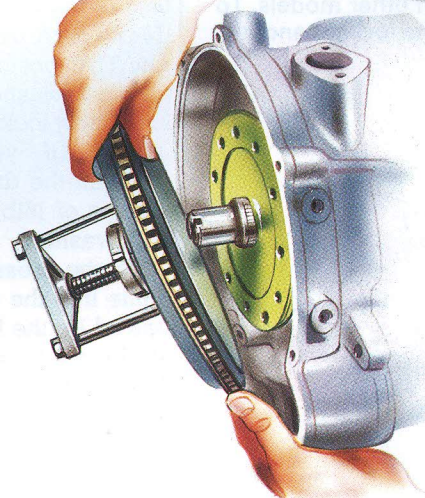

Releasing the clutch

Slide the friction plate off its splines on the primary gear, and lift out the pressure plate (1). If the holes in the drive straps are elongated (2) new straps are needed. If the old friction plate has worn out (3) it must be renewed – compare it with a new one if you are unsure how badly worn it is.

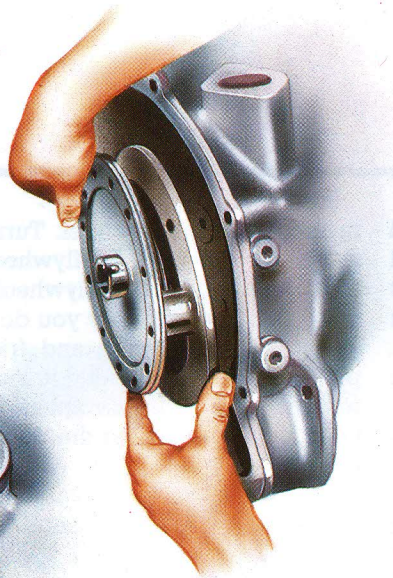

1 Pull the friction and pressure plates from the flywheel housing.

2 The drive strap holes should be perfectly circular.

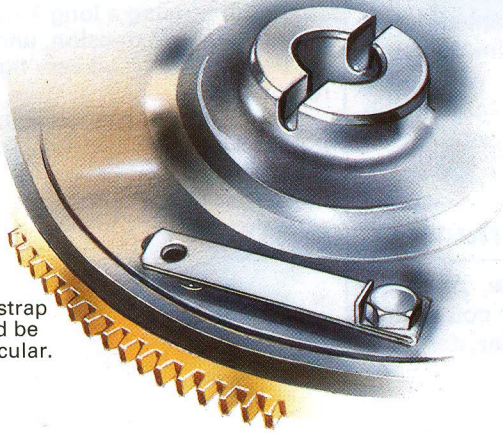

3 Compare the old plate with a new one to see the extent of the wear.

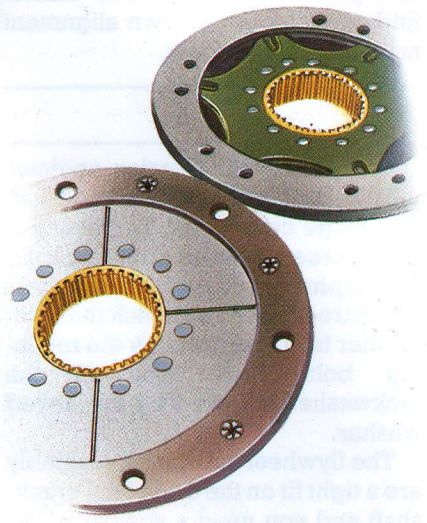

Adjusting the clutch

To adjust the throw-out stop, release its locknut and unscrew the stop to the limit of its thread. With a friend depressing the clutch pedal fully, turn the stop until it contacts the clutch housing, release the pedal and turn the stop by one more flat. Hold the stop in this position and tighten the locknut.

Where a lever stop bolt is fitted to the clutch cover, unhook the return spring and pull the lever away from the stop until all free movement is taken up. The gap between the lever and stop should be 0.020in (0.5mm) on the Mini and 1100/1300, and 0.040in (1mm) on other models. To adjust, slacken the locknut and turn the bolt.

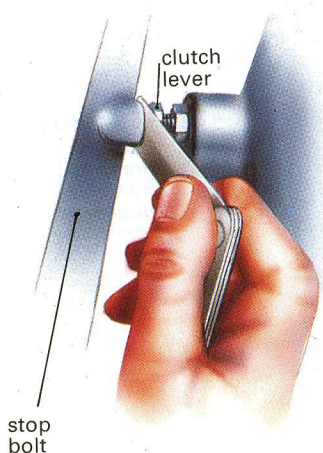

gear for signs of wear or damage. Replace any suspect components.

Reassembly

Assembly and replacement is essentially the reverse of dismantling and removal, but you should note the following points.

When reassembling the flywheel, pressure plate and diaphragm or spring plate, be sure to align the balance marks.

On all models, smear the splines of the primary gear with molybdenum disulphide grease.

A-series refit

Make sure the crankshaft is still in the TDC position with the open side of the C-washer facing downwards.

Fit new lockwashers to the driving straps (if you renewed them). Tighten the driving strap bolts to a torque of 16lb ft and bend over the lockwashers.

Fit the pressure plate and friction plate into the flywheel housing, followed by the flywheel. Temporarily fit the diaphragm bolts through the holes in the drive straps and into the pressure plate to pull the assembly together.

Refit the central flywheel retaining

bolt with a new lockwasher and tighten the flywheel bolt to 112lb ft. Bend over the lockwasher. Remove the diaphragm bolts, install the diaphragm, refit the bolts and tighten them to 16lb ft.

Refit all the other parts you removed, then if necessary adjust the clutch (see sideline left).

E-series refit

On E-series engines, assemble the pressure plate, friction plate and diaphragm to the flywheel. Offer up the whole assembly so that the splines in the clutch plate slide over those on the primary gear.

Rotate the flywheel to align the bolt holes in the flywheel with those on the crank (use the two dowels to help you – a mirror will be useful to see them). Then carefully tap the flywheel on part way with your soft hammer and fit the securing bolts with their large washer plate. Tighten them gradually to draw on the flywheel, and then to a torque of 60lb ft. Finally refit the thrust plate and tighten its bolts to 5lb ft and refit all the other parts you removed.

Check the fluid level in the clutch master cylinder and top it up to the correct level. Check it again after a few days to allow for settling.